

COLORADO 2

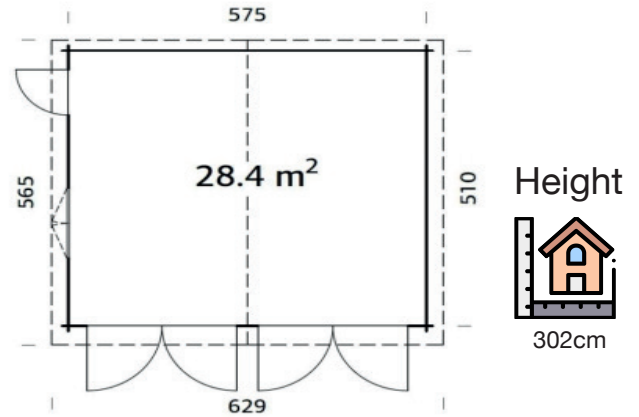

This double garage is 5.75m x 5.1m / 19ft x 16.5ft and is a perfect and secure place to store your vehicles or to use as a workshop. Possibly more of an upmarket barn than a timber garage, the Colorado 1 has an internal space of 28.4 sq m. That's enough for two cars, and quite a bit else besides - from your collection of unused sports equipment to your pet guinea pigs cage - whilst still providing enough room for some workstations at the back to keep tools and equipment on.



595 x 530cm



44mm



73.5m³



28.4m²



73 x 175,
221 x 188cm



119 x 89cm



N/A



19mm



N/A

FULL SPECIFICATION

CABIN SIZE:	595 x 530cm x 302cm
WALL THICKNESS:	44mm
VOLUME:	73.5m ³
AREA:	28.4m ²
DOOR OPENING:	73 x 175, 221 x 188cm
WINDOW OPENING:	119 x 89cm
FLOORS BOARDS:	N/A
ROOF BOARDS:	19mm
ROOF OVERHANG:	N/A
UNDER PLANNING:	No

Wood Type:	Nordic Spruce
Chalet Cut:	Logs (Wind & Rain Protection)
Window Type:	Double Glass
Window / Door Feature:	Rubber Seals & Silicone
Braces:	Wind Braces
Roof Boards With:	Boards With Tongue & Groove
Guarantee:	5 Years
Treated Foundation Joists:	No
IDEAL FOR:	GYM

FROM £6,806

**FINANCE FROM
£64.52PCM**

